

エバラSRM4型片吸込マルチエースファン  
EBARA SINGLE SUCTION MULTIACE FAN

極数 4P  
POLE 4P

トップランナーモータ搭載  
with top runner motor

外形寸法図  
DIMENSIONS

機名 MODEL 41/2SRM4

周波数 FREQUENCY 50 Hz

二重天井吊り  
HANGER TYPE

天井吊り形  
HANGER TYPE

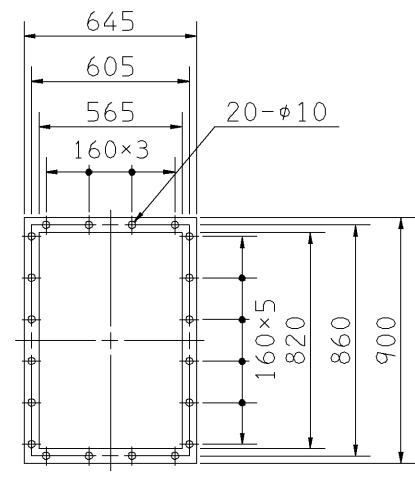
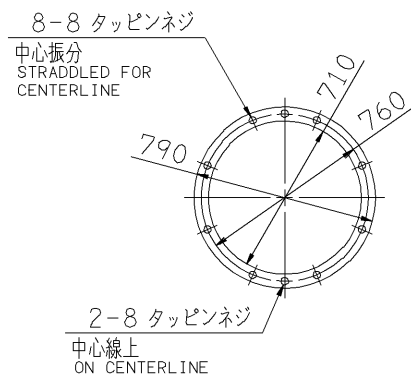
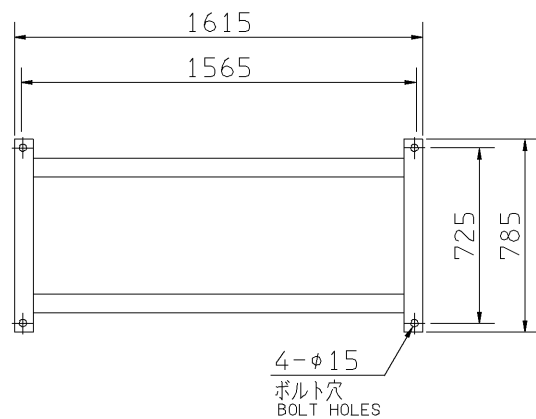
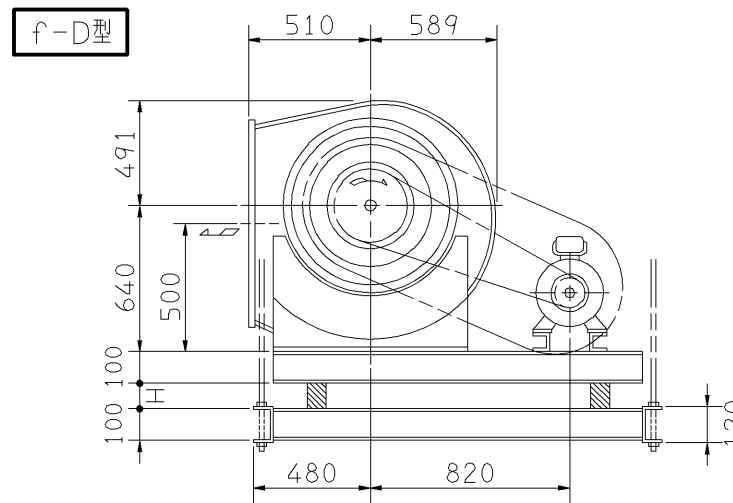
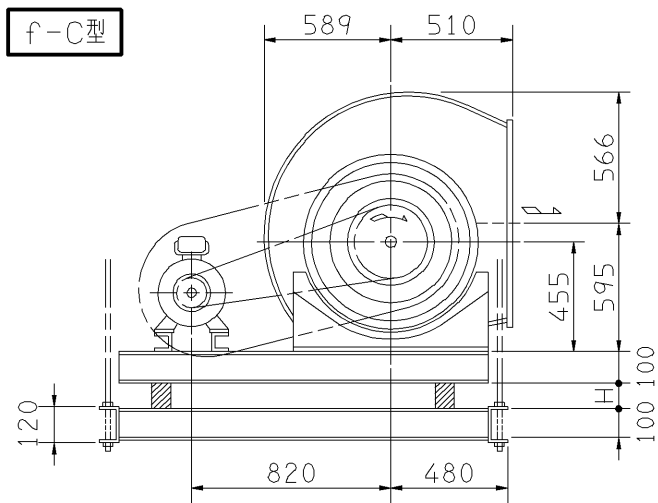
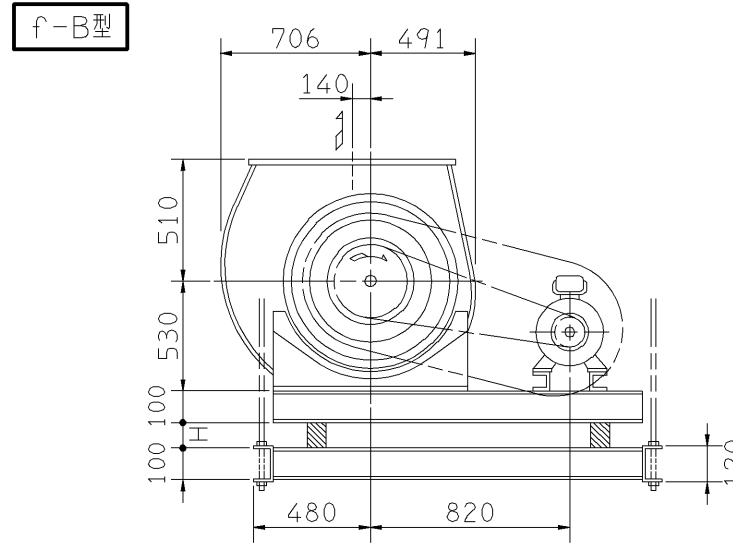
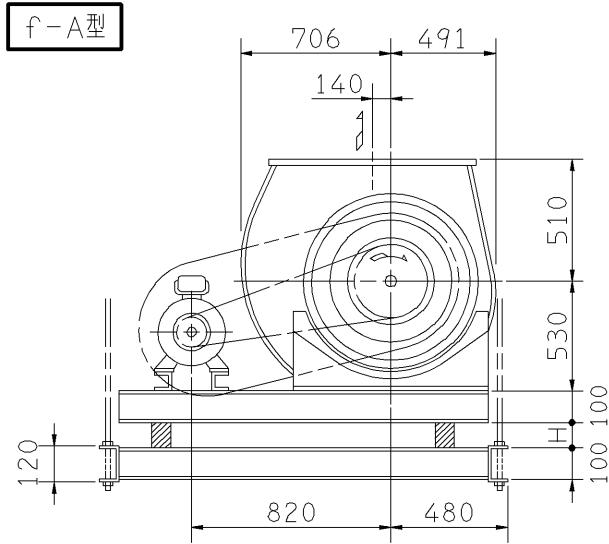
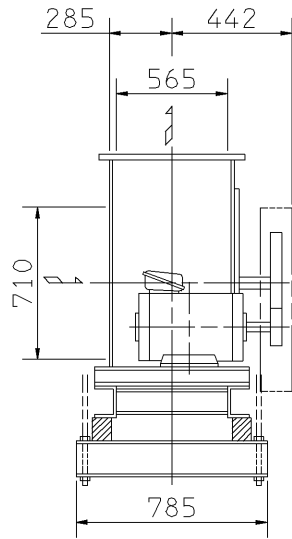

- 注) 1. 本図は、駆動側(プーリ側)より見た図です。  
NOTE DRAWING SHOWS THE DIMENSIONS VIEWED FROM PULLEY SIDE.  
2. 機器の取付け、配管等は取扱説明書を参照してください。  
FOR INSTALLATION PLEASE REFER INSTRUCTION MANUAL.  
3. 天井吊りボルトは付属いたしません。  
HANGER BOLTS ARE OUT OF SUPPLY.  
4. 本図は、エバラ標準電動機を使用した場合の図です。  
MOTORS ARE IN ACCORDANCE WITH EBARA STANDARDS.

出力 OUTPUT kW	回転速度 SPEED min <sup>-1</sup>	Vプーリ組合せ V PULLEY		Vベルト V BELT			概略 寸法 HEIGHT H	概略 質量 MASS kg		
		電動機側 MOTOR SIDE	ファン側 FAN SIDE	型 TYPE	数 Q'TY	呼称(号) SIZE f-A f-B f-C f-D				
1.5	315	67	315	3V	2	950	950	1000	20	230
	355	67	280	3V	2	950	900	950		
2.2	355	67	280	3V	2	950	900	950	20	240
	395	80	300	3V	2	950	950	1000		
3.7	395	75	280	3V	3	900	900	950	20	251
	440	75	250	3V	3	900	900	950		
	500	75	224	3V	3	900	850	950		
5.5	440	90	300	3V	3	950	950	1000	20	272
	500	95	280	3V	3	950	900	950		
	545	112	300	3V	2	950	950	1000		
7.5	500	110	315	3V	3	950	950	1000	20	287
	545	112	300	3V	3	950	950	1000		
	585	112	280	3V	3	950	950	1000		
	625	120	280	3V	3	950	950	1000		
11	545	112	300	3V	4	950	950	1000	20	317
	585	112	280	3V	4	950	900	950		
	625	120	280	3V	4	950	900	950		
	680	140	300	3V	3	950	950	1000		
	730	140	280	3V	3	950	950	950		

附属品 ACCESSORIES		特別附属品 SPECIAL ACCESSORIES		電動機 MOTOR		特殊仕様 SPECIAL SPEC.	
1	軸受(駆動側) UCF209 BG (PULLEY SIDE)	8	防振材(ゴム) ISOLATORS (RUBBER)	1	周波数 Hz	Hz	
2	軸受(反駆動側) UCP206 BG (OPPOSITE SIDE)	9	防振ベース VIBRO ISOLATING BASE	2	電圧 V	V	
3	Vプーリ V PULLEY	10		3	出力 kW	kW	
4	Vベルト V BELT	11		4	形式 TYPE		
5	Vベルトガード V BELT GUARD	12		5	メーカー MAKER		
6	共通ベース COMMON BASE	13		6			
7	相フランジ COMPANION FLANGE	14		7			

御注文主 CUSTOMER	機器番号 ITEM NO.					
御使用先 FINAL USER	機器名称 ITEM NAME					
荏原製番 SER.NO.	機名 MODEL	風量 CAPACITY	静圧 STATIC PRESS.	回転速度 SPEED	出力 OUTPUT	数量 Q'TY
				min <sup>-1</sup>		

図番 DWG.NO. Z41/2SRM45AC 000

Z41/2SRM45AC

